

Quality Air Solutions

Compressed Air Filters



Premium air purity for silicone-free applications

Superb quality air is a prerequisite in order to safeguard your instruments and ultimately your end product. Yet, when air is compressed, the concentration of dirt particles, oil carryover and moisture increases. To efficiently reduce all types of contamination with minimal pressure drop, Atlas Copco has designed a complete range of innovative filtration solutions for silicone-free applications such as painting. These filters are free from substances that could cause defects in the paint and clear your compressed air stream from solid particles that could cause contamination.



YOUR BENEFITS:

- Maximum contaminant removal
- Significant energy savings
- Limited system operating costs
- Increased reliability
- Easy maintenance



Atlas Copco

Technical specifications

DD, DDp, PD, PDp, QD AIR FILTERS

FILTER SIZE	Nominal capacity (1)		Maximum capacity (1)		Connections G or NPT	Dimensions						Free space for cartridge replacement		Weight	
	l/s	cfm	l/s	cfm		A		B		C		D		kg	lbs
DD, DDp, PD, PDp, QD						mm	in	mm	in	mm	in	mm	in	kg	lbs
9	9	19	11	23	3/8	90	3.54	61	2.40	268	10.55	75	2.95	1	2.2
17	17	36	21	45	1/2	90	3.54	61	2.40	268	10.55	75	2.95	1.1	2.4
32	32	68	40	85	1/2	90	3.54	61	2.40	323	12.72	75	2.95	1.3	2.9
44	44	93	55	117	3/4 & 1	110	4.33	98.5	3.88	374	14.72	75	2.95	1.9	4.19
60	60	127	75	159	1	110	4.33	98.5	3.88	414	16.3	75	2.95	2.1	4.6
120	120	254	150	318	1-1/2	140	5.51	105	4.13	520	20.47	100	3.94	4.2	9.3
150	150	318	188	399	1-1/2	140	5.51	105	4.13	603	23.74	100	3.94	4.5	9.9
175	175	371	219	464	1-1/2	140	5.51	105	4.13	603	23.74	100	3.94	4.6	10.1
280	280	594	350	742	2 & 2-1/2	179	7.05	121	4.76	689	27.13	150	5.91	6.9	15.2
390	390	827	488	1035	3	210	8.27	128	5.04	791	31.14	200	7.87	11	24.2
520	520	1102	650	1378	3	210	8.27	128	5.04	961	37.83	200	7.87	12.6	27.8

(1) Nominal pressure: 7 bar(e)/102 psig; temperature 20°C, 68°F

Maximum air inlet temperature
 DD/DDp/PD/PDp: 66°C (151°F)
 QD: 35°C (95°F)

PRESSURE DROP

	DD	DDp	PD	PDp	QD
Initial pressure drop at nominal capacity (dry)	0.05	0.05	0.08	0.08	0.07
Initial pressure drop at nominal capacity (wet)	0.12	N/A	0.2	N/A	N/A

For other compressed air inlet pressures, multiply the filter capacity by the following correction factors:

Inlet pressure	bar	2	4	6	7	8	10	12	14	16
Inlet pressure	psig	29	58	87	102	116	145	174	203	232
Correction factor		0.53	0.75	0.92	1	1.06	1.2	1.31	1.41	1.5

N/A: Not applicable.

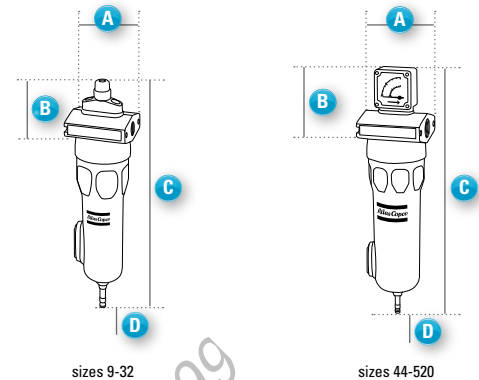

Gotek Vietnam Ltd.
 www.gotek.com.vn
 (090) 696-6535 or (093) 820-5599



Never use compressed air as breathing air without prior purification in accordance with local legislation and standards.



www.atlascopco.com